

# LIFT WITH EASE

Efficient and ergonomic  
material handling





Item No.: Classic B-M

## Classic B-M



Weight (kg)	7.5
Maximum capacity (kg)	100
Type of lifting object	Luggage, Bin, Bucket, Cardboard box, Metal, Pallet, sack, sheet
Function	Rotation
Height (mm)	586
Configuration height (mm)	-579
Other characteristics	Stainless steel (SS)



When you need a lifting tool that meets all the requirements of an ergonomic material-handling aid, and works for almost all lifting tasks, the Classic B-M is the one to turn to. One of the most distinguishable features of the Classic B-M is its configurability. The variety of handles and interchangeable applications available with the Classic B-M makes this lifting tool compatible with your specific material handling needs, regardless of what you intend to lift and how you need to move it.

### Impressive maximum capacity

When it comes to dealing with heavy and hard-to-reach goods, the Classic proves it can handle most of these with ease. With a maximum lifting capacity of 100 kg, this lifting tool is ready to tackle the most demanding lifting maneuvers and perform them effortlessly. Whether you need to lift large quantities of material or heavy goods, you can trust that the Classic B-M will get the job done.

### Interchangeable Applications

A key component in the Classic B-M's versatility is its interchangeable applications. Tell us what you want to lift, and we'll equip your Classic with the best application for the job. Regardless of the load you need to lift, barrels, sacks, boxes or other objects of different materials and formats, the Classic B-M will have the right application for you. The applications for the Classic are the same as the ones used with our bestseller, the Basic. These including the H-Frame,

I-Frame, hooks and sack lifting vacuum suction cups, etc., all with the same technique for changing applications - the twist. Interchangeable applications provides you with added flexibility of using one machine to lift a range of different products in your work place.

### **Adaptable handles**

From high to low lifting, the Classic B-M comes with an assortment of handles that can be mounted onto it. Whether you need to load pallets, place packets in postal boxes, pick from pallets racing around on a conveyor belt, or just reach the back of a shelf, the Classic B-M has the right handle for the job. Choose between a Classic B-M with a long, short, or angled handle for extra stability, or a single handle for more flexibility. With the right handle, you'll be able to reach higher up, farther back, deeper down and even stack goods on top each other.

### **Experience a versatile tool**

The Classic B-M is the ultimate vacuum lifting tool for all who need versatility, power and agility when it comes to material handling. With its impressive lifting capacity, interchangeable applications, customizable handles and possibility to choose between a rotatable or fixed joint, it is the perfect companion for those who strive for safe and easy material handling.

**Here you can see a selection of Applications that are suitable for Classic B-M:**

## Further information



### [Single cups](#)

Single cups are vacuum cups equipped with a bayonet coupling that easily connects them to and from the Classic B-M. Depending on the size and weight of the load, and whether it is dense or porous - there is a wide range of vacuum cups to choose from.



### [I-Frames](#)

I-frames are available in different variants to lift different heavy loads depending on whether they are porous or dense. The frames consist of two vacuum cups on a powder-coated frame and are well suited for lifting elongated objects such as cartons, tubes or pipes. By adding a cellular rubber, the vacuum cups get an even better grip when gripping over straps.



### [H-frames](#)

H-frames lift porous and dense packages efficiently. The H-shaped design allows the cups to grip the corners and avoid the tape seam, where the vacuum would otherwise have a weaker hold. The same vacuum cups can be used for plastic boxes and sheet metal parts, and the use of cellular rubber further improves the grip, especially over .



### [Sack Suction Heads](#)

Bag suction feet are suitable for lifting both sacks and baggage of different sizes and weights.



### [Vacuum Pads](#)



The vacuum pad is the application we recommend for those who want to be able to lift several different types of objects with the same lifting tool, such as boxes, metal sheets with holes in them or other loads that are not completely smooth. The application lifts the load gently and is therefore perfect to use for loads that should be handled carefully.



### [Hooks](#)

We offer several different types of hooks for lifting buckets, cans or pallets. The hooks are available in different formats from safety hook to a simple hook and are controlled up and down with Basic's buttons.

## Versions

Article number	Weight (kg)	Maximum capacity (kg)	Type of lifting object	Function	Height (mm)	Configuration height (mm)	Other characteristics
 92-10065-SS		100			586	579	Stainless Steel
 92-10065-MK2	7-5	100		Rotation	586	579	

## Drawings

Rev	Nature of change/change message	Date	Approved by

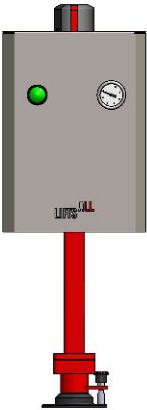
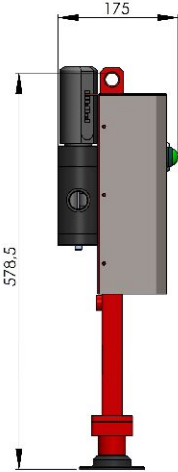
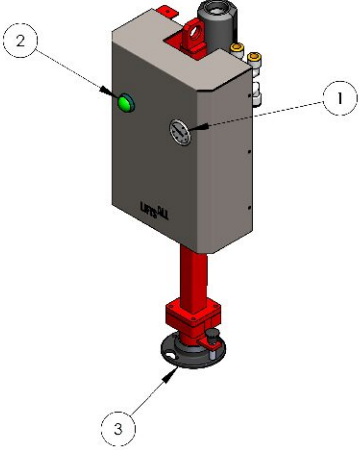

ITEM NO.	QTY.	Drawing Number	Article number	Description
1	1	Vacuum gauge	12-10460	Vacuum gauge
2	1	-	40-10032	Green Eye
3	1	RT205678	16-10408	Bayonet bracket 1

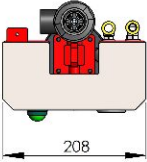
General tolerances Tolerances if not indicated: ISO 2768-1-m ISO 13920-B ISO 5817 C Sharp edges broken	Surface tolerances -	Material/Reference Designated by GH Checked Project Lifts All AB Project number R023186	Project/Item Design code 250109 Checked date Description Classic B-M, max load 100 kg Article number 92-10065-MK27452	Project/Item Scale 1:5 Format A3 Sheet n°/N° 1/1 Revision
---	-------------------------	--	--	--



## CONTACT US

### USA

Lifts All Inc.  
728 William Blount Dr,  
Maryville, TN 37801  
USA  
E-mail: [info@liftsall.us](mailto:info@liftsall.us)  
Telephone: +1 865-324-2014  
Website: [liftsall.com](http://liftsall.com)

### HEAD OFFICE WORLDWIDE

Lifts All AB  
Passadvägen 10  
176 67 Järfälla  
Sverige  
E-mail: [lifting@liftsall.se](mailto:lifting@liftsall.se)  
Telephone: 08-754 90 15  
Website: [liftsall.com](http://liftsall.com)