

# LIFT WITH EASE

Efficient and ergonomic  
material handling





Item No.: 92-10060-Mk2

## Roll gripper [120]kg - Tilt (90 degrees)



Weight (kg)	28
Maximum capacity (kg)	120
Type of lifting object	Roll
Function	Tilt
Industry	Beverage industry, Pharmaceutical industry, Food industry, Metal industry, Distribution and warehousing, Wood and furniture industry, Ventilation industry, Engineering industry
Height (mm)	1350, 740
Configuration height (mm)	-1077

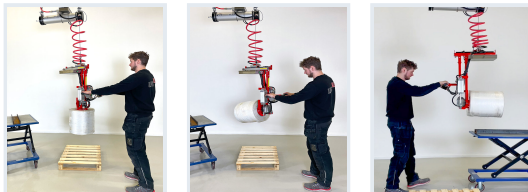

Lifts All's roll gripper makes lifting rolls easy. The gripper has an expanding silicone ring, that grips the roll by its core without damaging the material on the outside. Then, the roll can be tilted into a horizontal or vertical position, depending on how you want to place it. The gripper is easily maneuvered, making it simple to place rolls into shelves or in machines. The operator can get the job done without any strenuous manual lifting. Rolls become completely weightless with this gripper.

### Adaptable for different rolls

The roll gripper can lift most rolls or coils with a hollow core. It can, for example, lift paper rolls, foil rolls, aluminum rolls or plastic rolls. Using the simple PSH control is easy, and placing the roll down precisely is a synch. It doesn't take up unnecessary space and has low energy consumption. This particular roll gripper can lift very heavy rolls, up to 120 kg. Its lifting capacity is completely adjustable. If you need to lift heavier or lighter rolls, we can tailor make a lifting solution for you.

### Roll gripper for different industries

Within Lifts All's range of roll grippers, there are grippers that can lift, rotate, tilt, mount and move rolls. This makes the roll gripper a popular choice for manufacturing industries where heavy manual lifting is being phased out. Such as, in the paper industry, timber companies and the beverage industry. With

our flexible lifting tools operators can work more ergonomically and be freed from the unsustainability of manual lifting.

## Further information



### Expanders

The expander applications fit different rolls depending on the size of the core. The piston grips the core of the roll and expands, making it possible to lift rolls up to 120 kilos. Expander 92-10061 is 76mm wide and expander 92-10062 is 152mm wide.

## Drawings

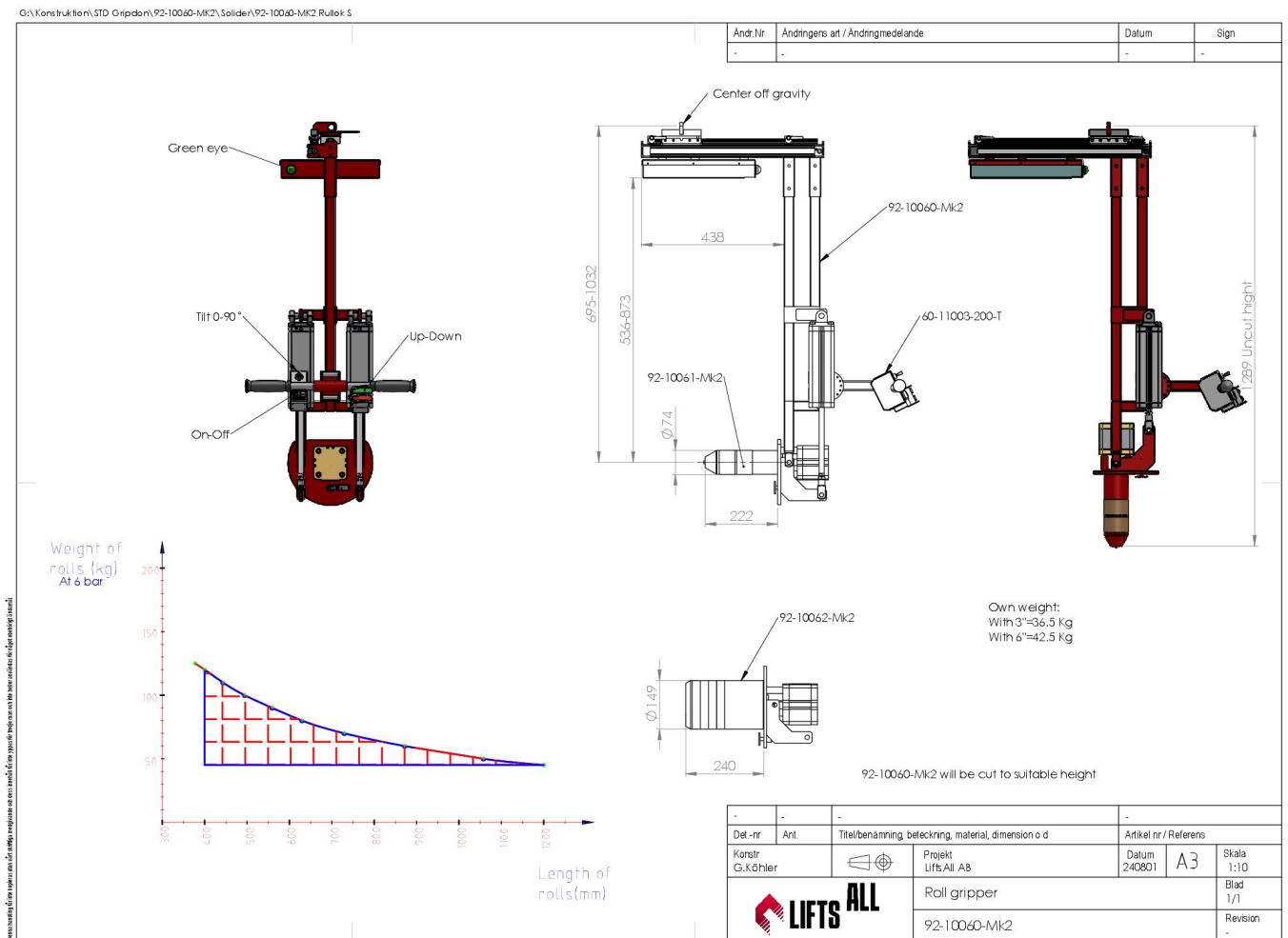



## **CONTACT US**

### **USA**

Lifts All Inc.  
728 William Blount Dr,  
Maryville, TN 37801  
USA  
E-mail: [info@liftsall.us](mailto:info@liftsall.us)  
Telephone: +1 865-324-2014  
Website: [liftsall.com](http://liftsall.com)

### **HEAD OFFICE WORLDWIDE**

Lifts All AB  
Passadvägen 10  
176 67 Järfälla  
Sverige  
E-mail: [lifting@liftsall.se](mailto:lifting@liftsall.se)  
Telephone: 08-754 90 15  
Website: [liftsall.com](http://liftsall.com)